

Technical training.
Product information.

I01 Body Repair Level 1



BMW Service

Edited for the U.S. market by:

BMW Group University
Technical Training

ST1403a / SB026

4/1/2014

General information

Symbols used

The following symbol is used in this document to facilitate better comprehension or to draw attention to very important information:



Contains important safety information and information that needs to be observed strictly in order to guarantee the smooth operation of the system.

Information status and national-market versions

BMW Group vehicles meet the requirements of the highest safety and quality standards. Changes in requirements for environmental protection, customer benefits and design render necessary continuous development of systems and components. Consequently, there may be discrepancies between the contents of this document and the vehicles available in the training course.

This document basically relates to the European version of left-hand drive vehicles. Some operating elements or components are arranged differently in right-hand drive vehicles than shown in the graphics in this document. Further differences may arise as the result of the equipment specification in specific markets or countries.

Additional sources of information

Further information on the individual topics can be found in the following:

- Owner's Handbook
- Integrated Service Technical Application.

Contact: conceptinfo@bmw.de

©2013 BMW AG, Munich

Reprints of this publication or its parts require the written approval of BMW AG, Munich

The information contained in this document forms an integral part of the technical training of the BMW Group and is intended for the trainer and participants in the seminar. Refer to the latest relevant information systems of the BMW Group for any changes/additions to the technical data.

Information status: **July 2013**
BV-72/Technical Training

I01 Body Repair Level 1

Contents

1. Introduction	1
1.1. Body Repair Level 1	1
1.2. Body Repair Level 2+3	1
1.3. High-voltage system	2
2. Outer Body Panels	3
2.1. Overview	3
2.2. Front door	4
2.3. Rear door	6
2.4. Front fender	8
2.5. Rear quarter panel	11
2.6. Tailgate	13
2.7. Bumper	14
2.8. Side sill trim panel	14
2.9. A-pillar and roof frame trim panel	15
3. Add-on Body Parts	16
3.1. Design and adjusting procedures	16
3.1.1. Front doors	16
3.1.2. Rear doors	18
3.1.3. Engine compartment lid	21
3.1.4. Tailgate	23
3.2. Screw-on elements, Drive module	26
3.3. Sliding/tilting sunroof	27
3.4. Windshield	29
3.5. Rear window	31
3.6. Rear side window	31
4. Repair	33
4.1. Reconditioning of outer panels	33
4.1.1. Plastic bonding	34
4.1.2. Plastic welding	34
4.2. Repair of fixing rails	35
4.3. Repairing door window frames	35
4.4. Repair of screwed deformation elements	36
4.5. Repair of ground support points	36
5. Body Damage	37
5.1. Notes	37

I01 Body Repair Level 1

1. Introduction



Note

Please observe beforehand the information in the Training Reference Manual "i3 product presentation" about the body and interior concept.



1.1. Body Repair Level 1

Innovations in the area of body outer panels of the i3 are presented in this document.

Based on repair stage 1 of the workshop information system ISTA by BMW, the i3 "Body Repair Level 1" includes the following repair work:

- The exchange of parts of the body outer panels and their reconditioning
- The exchange of fixing rails
- The exchange of screwed body components.

This repair work may only be carried out by authorized BMW i dealers. If the damage to the vehicle cannot be repaired during the course of the i3 Body Repair Level 1, the vehicle must be passed on to a BMW i dealer with the relevant service format. Please observe the current procedure that applies in your market.

Service format	Activities
 ST1403a must be completed.	Body Repair Level 1
 Full service includes ST1403a and ST1403b in conjunction with a BMW i Certified Collision Repair Center with SB026 and SB026A.	Body Repair Level 1+2+3

1.2. Body Repair Level 2+3

Based on repair stages 2+3 of the workshop information system ISTA by BMW, the i3 Body Repair Level 2+3 encompasses the following repair work:

I01 Body Repair Level 1

1. Introduction

- Bonding of body structure components made of carbon with and without using a straightening bench
- Bonding and riveting of aluminium body structure components with and without using a straightening bench or special tool for mounting the Drive module.

The contents of the i3 Body Repair Level 2+3 are not part of this document and are not discussed in the training reference manual. The training information on the level 2+3 body repair will be covered during the instructor led training course provided by the Body & Paint Training Center. Repair work for the i3 Body Repair Level 2+3 may only be performed at a BMW i Certified Collision Repair Center by a trained Collision Repair Technician who has successfully completed the “I01 Body Learning Path”.

1.3. High-voltage system



Danger to life!

The i3 is equipped with many high-voltage components. Before working on or near high-voltage components, the vehicle must be de-energized by a certified hybrid/high voltage technician that has successfully completed the i3 Complete Vehicle Training.

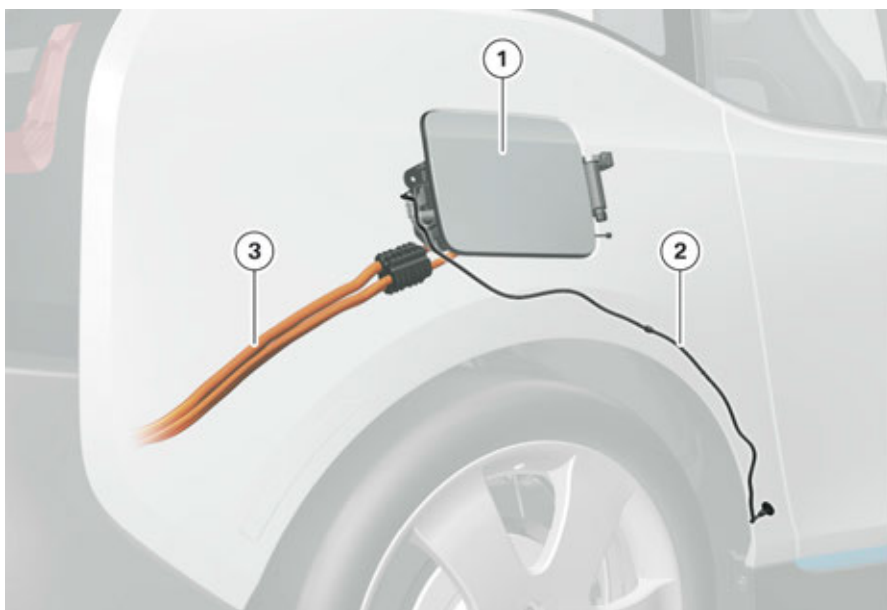

Rear side panel on right

Index	Explanation
1	Charging socket
2	Emergency release for flap of charging socket
3	High-voltage cable

I01 Body Repair Level 1

2. Outer Body Panels

2.1. Overview

This chapter shows examples of operations involved in the disassembly and installation at the outer panels of the i3. Furthermore, adjusting procedures are described in detail using the current repair instructions in the BMW workshop information system.

The outer panels of the i3 is made almost entirely of thermoplastic plastics (material designation: PP +EPDM). The plastic outer panels components are designed to ensure the gap dimensions are up to BMW standards, even when subjected to strong temperature fluctuations. The plastic outer panels components cannot corrode and are considerably lighter than steel. The outer panels are clipped or screwed to the i3 body by additional fixing rails made of plastic or retaining elements.

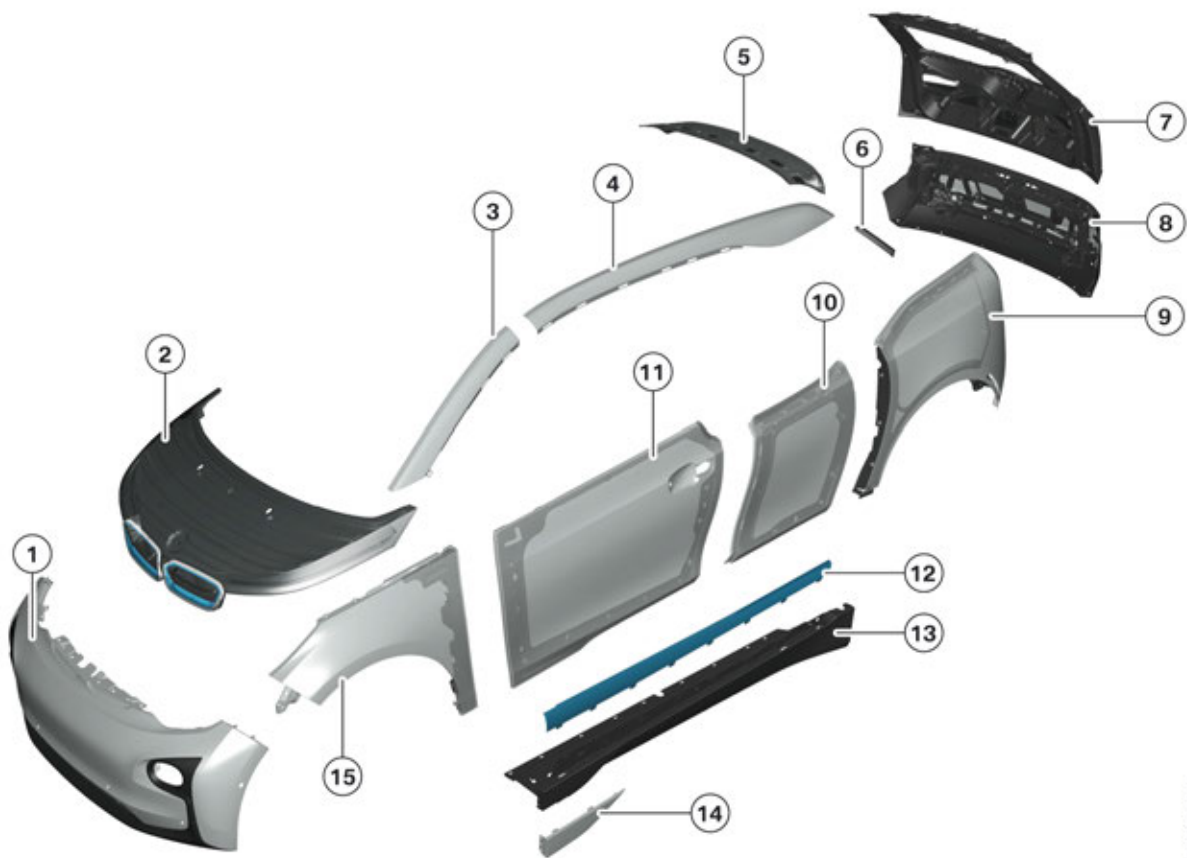

TK12-1108

Exploded view of the i3 outer panels

Index	Explanation
1	Bumper, front
2	Engine compartment lid (outer panels)
3	Trim panel, A-pillar front
4	Roof frame trim panel
5	Rear spoiler
6	D-pillar cover

I01 Body Repair Level 1

2. Outer Body Panels

Index	Explanation
7	Tailgate frame with outer panels
8	Rear bumper
9	Rear side panel
10	Rear door outer panels
11	Front door outer panels
12	Side sill trim at top
13	Side sill trim at bottom
14	Side sill trim at front
15	Front side panel

Fixing rails, outer panels components and hinges are fastened to structural components made of carbon. The following new retaining elements are used for this.



i3 retaining elements

Index	Explanation
1	Locking nut
2	Attachment point on carbon with mounting plate on reverse side
3	Bonded retaining element with stud bolt



Refer to the repair instructions for the proper tightening torques to avoid damaging the retaining elements and structural components made of carbon.

2.2. Front door

The outer panels of the front door consists of two plastic parts that have already been bonded as part of the production process and guarantee a secure connection with the aluminium door frame.

I01 Body Repair Level 1

2. Outer Body Panels

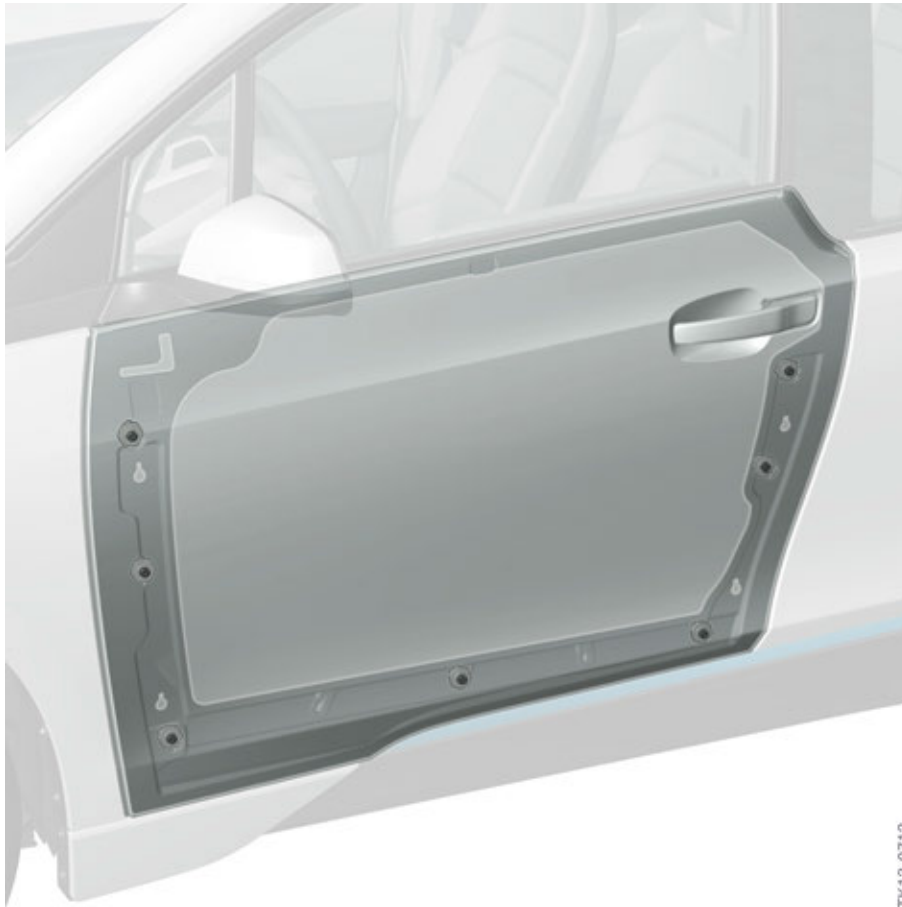

i3 front door outer panels

The outer panels of the front door is fastened to the aluminium door window frame with clips.

The mounting brackets for the fastening clips of the outer panels are equipped with a threaded adjuster by which the outer panels can be adjusted crosswise in relation to the direction of travel. This ensures that the outer panels is in the optimum position.



The fastening clips of the door outer panels can only be used once.

I01 Body Repair Level 1

2. Outer Body Panels

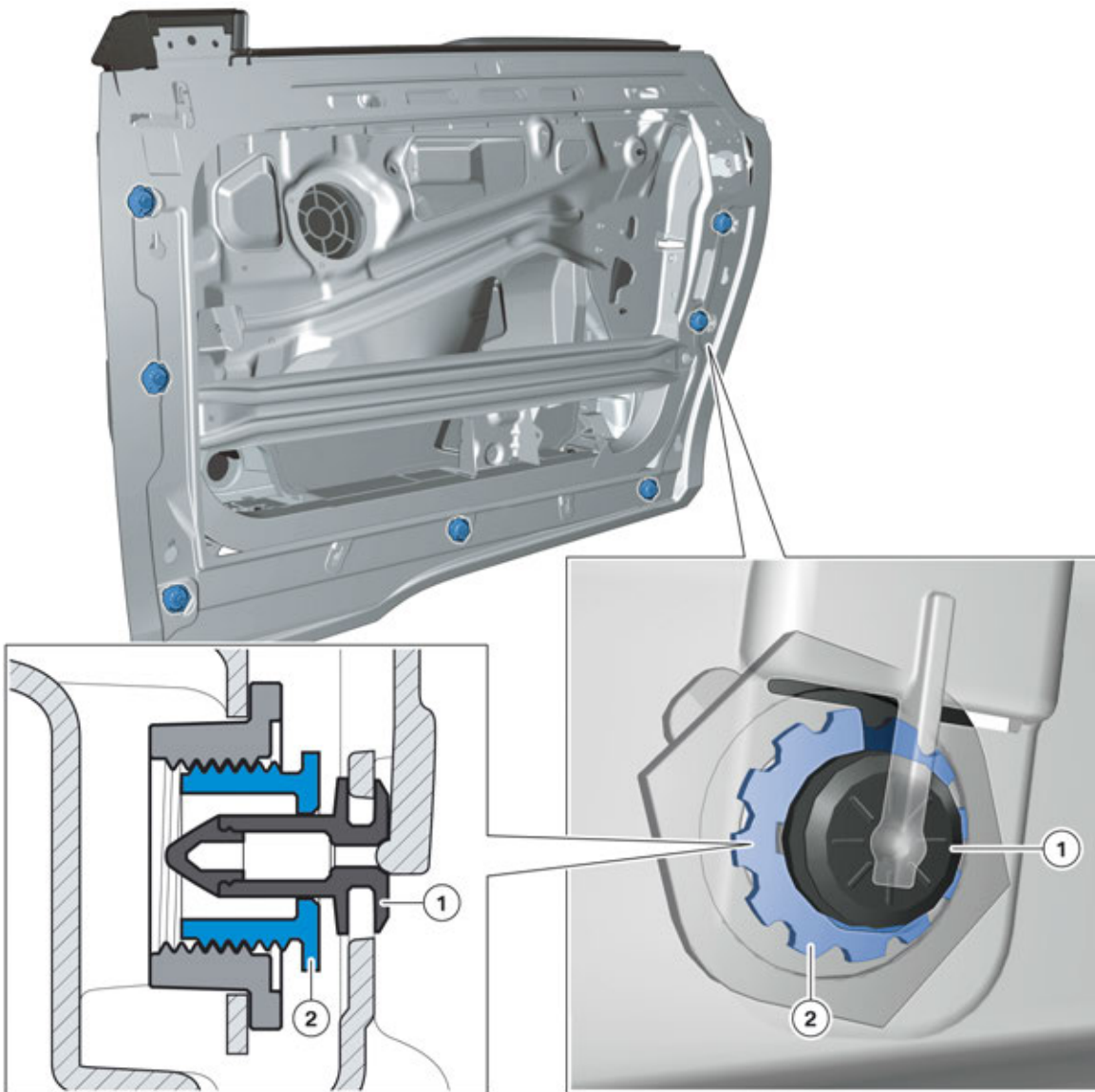

TK12-1110

Mounting of outer panels, front door

Index	Explanation
1	Clip
2	Adjusting element

2.3. Rear door

The fastening concept and design of the rear door outer panels is similar to the front door. This ensures in this case that the plastic outer panels can also be adjusted crosswise in relation to the direction of travel.

I01 Body Repair Level 1

2. Outer Body Panels



i3 rear door outer panels

The outer panels is also fastened with clips and expanding rivets to the carrier housing of the rear door. These can be rotated out of the stop position once the interior trim has been disassembled.

I01 Body Repair Level 1

2. Outer Body Panels

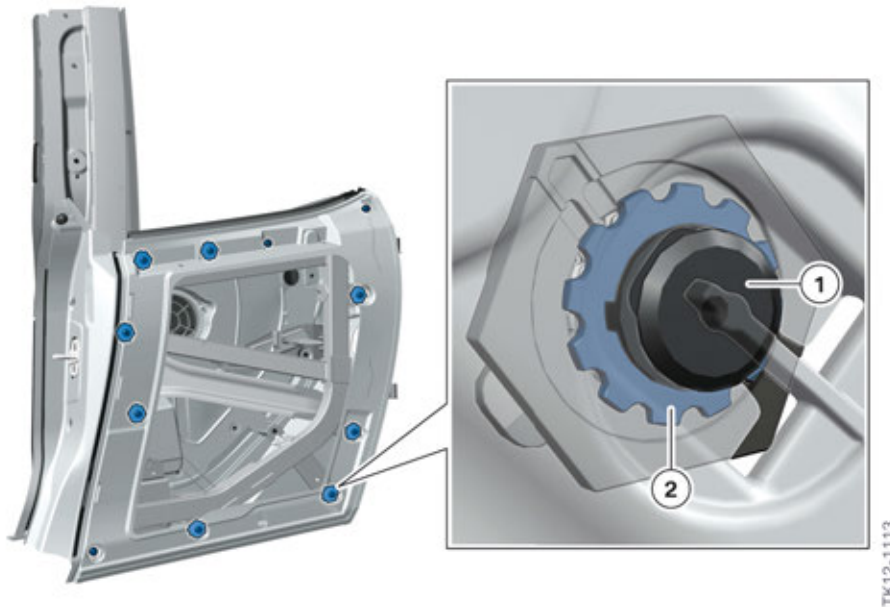

i3 mounting of rear door outer panels

Index	Explanation
1	Clip
2	Adjusting element

2.4. Front fender

The front side panel is made of plastic and is fastened by clips and screws. A retaining element is glued to the rear section of the fender during production which ensures optimum mounting.

I01 Body Repair Level 1

2. Outer Body Panels

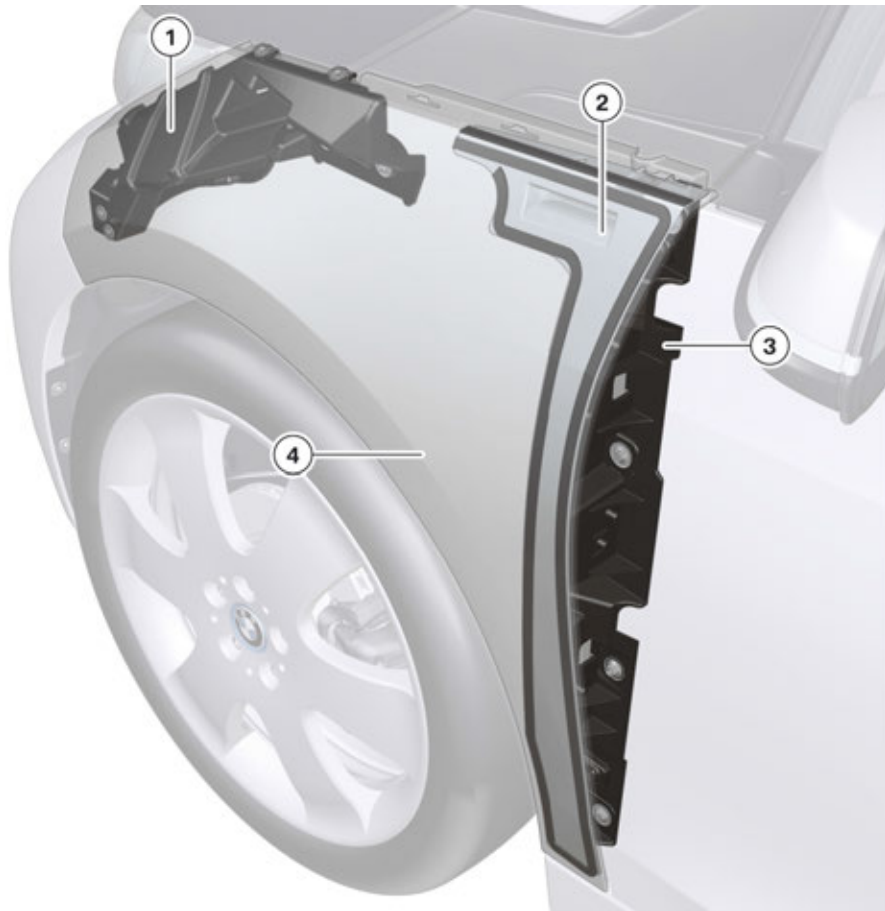

Front side panel with brackets

Index	Explanation
1	Retaining strip, front
2	Retaining element of fender
3	Rear fixing rail
4	Front fender

Adjusting procedures are performed by the elongated holes of the screw connections in the area of the engine compartment lid and the cover of the A-pillar. For the gap dimensions, refer to the repair instructions.

The screw points for the fender on the wheel arch side are on the rear fixing rail and also at the front on the bumper. A fixing rail at the front made of plastic acts as an additional carrier element and is screwed to the spring strut dome and the support at the top.



The fixing rail which is screwed to the side frame may only be fastened with the prescribed tightening torque to avoid damaging the carbon structure.

If the i3 is equipped with a Range Extender, the fuel filler neck will be in front side panel on the right.

I01 Body Repair Level 1

2. Outer Body Panels

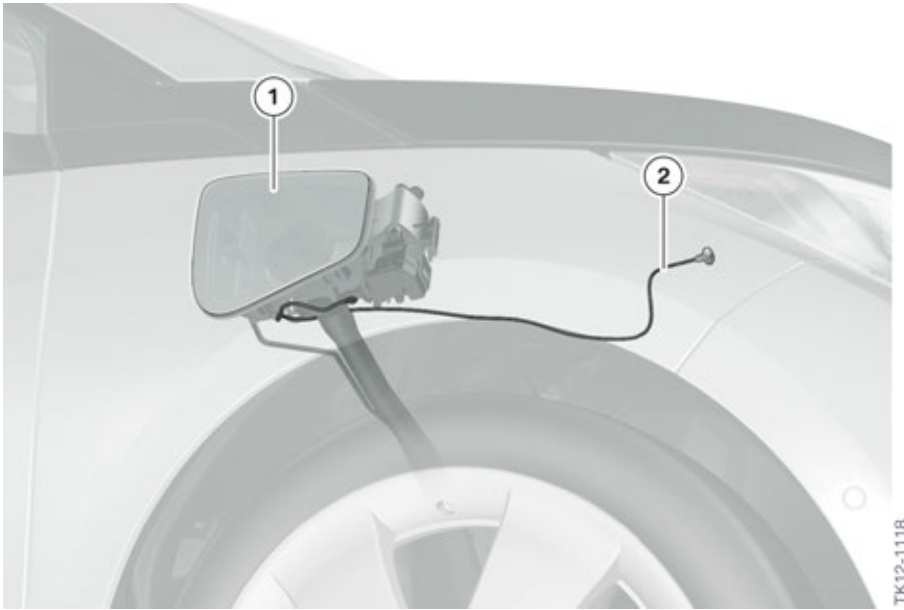

Front side panel right

Index	Explanation
1	Fuel filler flap
2	Emergency release

The fuel tank is located behind the front axle in the Drive module. The routing and installation locations of the fuel lines are shown in the following graphic.

I01 Body Repair Level 1

2. Outer Body Panels

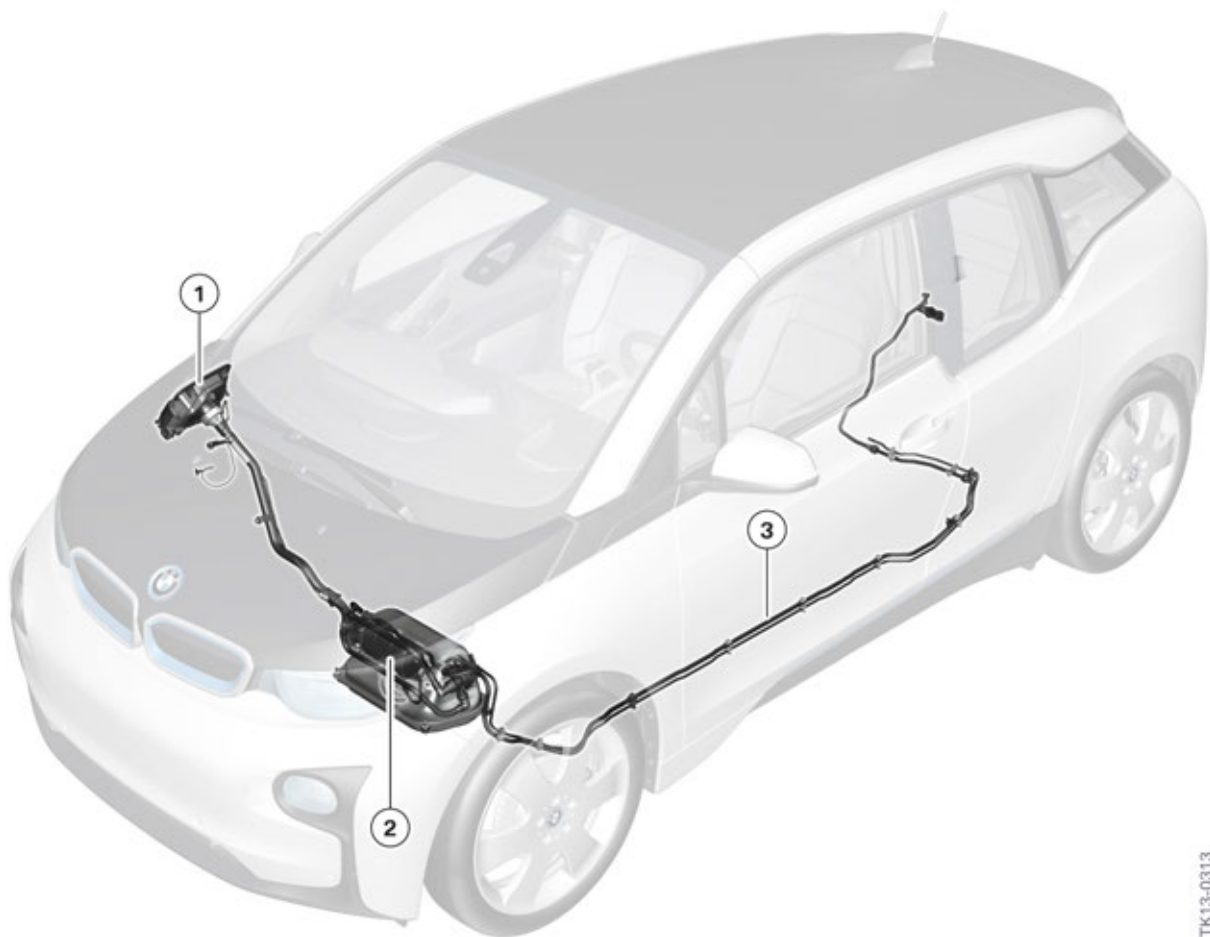

TK13-0313

Fuel system i3 with Range Extender

Index	Explanation
1	Fuel filler neck
2	Fuel tank
3	Fuel line

2.5. Rear quarter panel

The quarter panel also consists of two components made of plastic which are bonded together. Two additional fixing rails for mounting the quarter panel are attached to the carbon structure.

The components of the charging socket for the high-voltage battery are installed in the quarter panel on the right.

I01 Body Repair Level 1

2. Outer Body Panels



i3 mounting of rear side panel

Index	Explanation
1	Retaining strip, front
2	Rear fixing rail
3	Retaining element of quarter panel

The rear quarter panel is fastened at the top by the fixing rail at the rear with the help of retaining tabs.

The quarter panel is screwed in the area of the tailgate, wheel arch cover and rear passenger compartment entrance. There are mountings in the form of retaining tabs in the area of the side window and rear bumper. The fixing rail for the quarter panel is screwed to the side frame and bumper guide respectively.



Refer to the repair instructions for the prescribed tightening torques to avoid damaging the retaining elements and structural components made of carbon.

I01 Body Repair Level 1

2. Outer Body Panels

2.6. Tailgate

The outer panels of the tailgate of the i3 has for the first time been manufactured from glass. The rear lights can therefore be integrated below the outer panels.



TK13-0316

Scope of replacement parts, tailgate

If damaged, the outer panels of the tailgate can only be replaced as shown with the tailgate frame as a new part.

The rear spoiler of the i3 is fastened by a clip to the tailgate frame. The clips have been designed so that the rear spoiler can be adjusted.

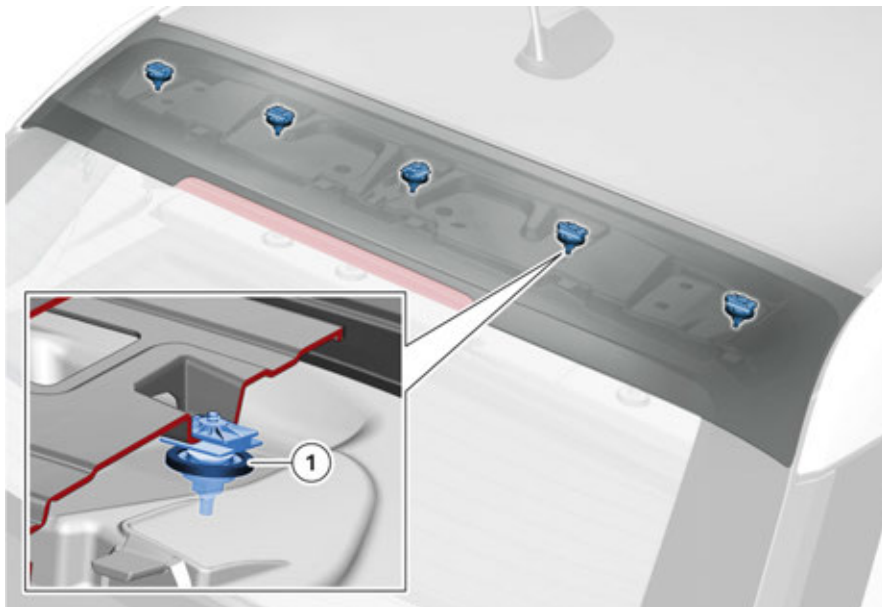

TK13-0301

Rear spoiler with adjusting elements

I01 Body Repair Level 1

2. Outer Body Panels

Index	Explanation
1	Adjusting element

The screwed rear spoiler can be disassembled by detaching the interior trim panel.

2.7. Bumper

The front and rear bumper have been made in several sections. The plastic parts are connected by retaining tabs. The assembled bumpers are attached to the adjacent body components, this method is used in other BMW vehicles.

2.8. Side sill trim panel

The side sill trim panel has three sections and is manufactured entirely from thermoplastics (PP +EPDM). The side trim panel at the top is a BMW i design element which is usually blue in color.

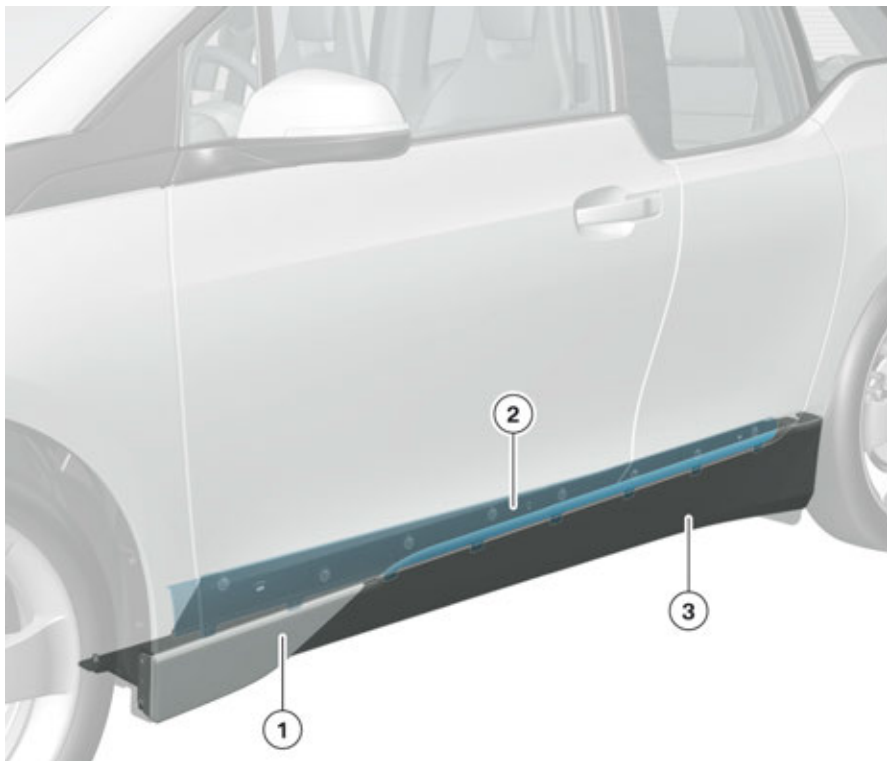

Side sill trim panel

Index	Explanation
1	Side sill trim at front
2	Side sill trim at top
3	Side sill trim at bottom

The side sill trim panel at the bottom is connected to the Life module by rivet nuts and screws.

I01 Body Repair Level 1

2. Outer Body Panels



Refer to the repair instructions for the prescribed tightening torques to avoid damaging the retaining elements and structural components made of carbon.

The side sill trim panels at the front and top are connected to the side sill trim panel at the bottom by retaining tabs.

2.9. A-pillar and roof frame trim panel

An new concept is also used with the A-pillar and roof frame trim panel in the i3.

A thermoplastic with the material designation PC+PET is used for the A-pillars and roof frame trim panel, instead of the thermoplastic plastic with the material designation PP+EPDM which is used for example with the door outer panels.

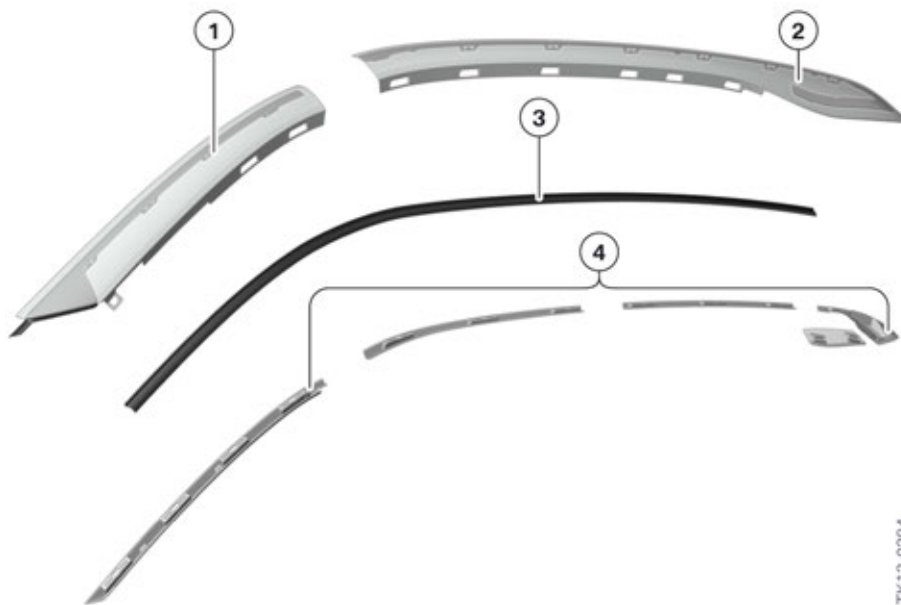

B-pillar trim panels with fixing rails and gaskets

Index	Explanation
1	A-pillar trim panel
2	Roof frame trim panel
3	Gasket
4	Fixing rails

The concept of the outer panels is pursued further in the A-pillar trim panel and roof frame trim panel. The A-pillar trim panel and roof frame trim panel are therefore implemented by bonding several components at the production stage so that they can be attached to the body by retaining tabs. The retaining tabs in this case engage with fixing rails which are glued to the side frame of the Life module. The A-pillar trim panel is also screwed at the bottom edge in combination with a rivet nut in the carbon structure.

I01 Body Repair Level 1

3. Add-on Body Parts

3.1. Design and adjusting procedures

3.1.1. Front doors

When compared to a conventional steel door design, there are a significantly higher number of individual components in the doors of the i3. The aluminium door window frame in combination with the remaining plastic parts ensures a light and stable design. The door outer panels consists of two parts which are permanently connected at the production stage. The retaining elements are mounted on the inner section of the door outer panels.

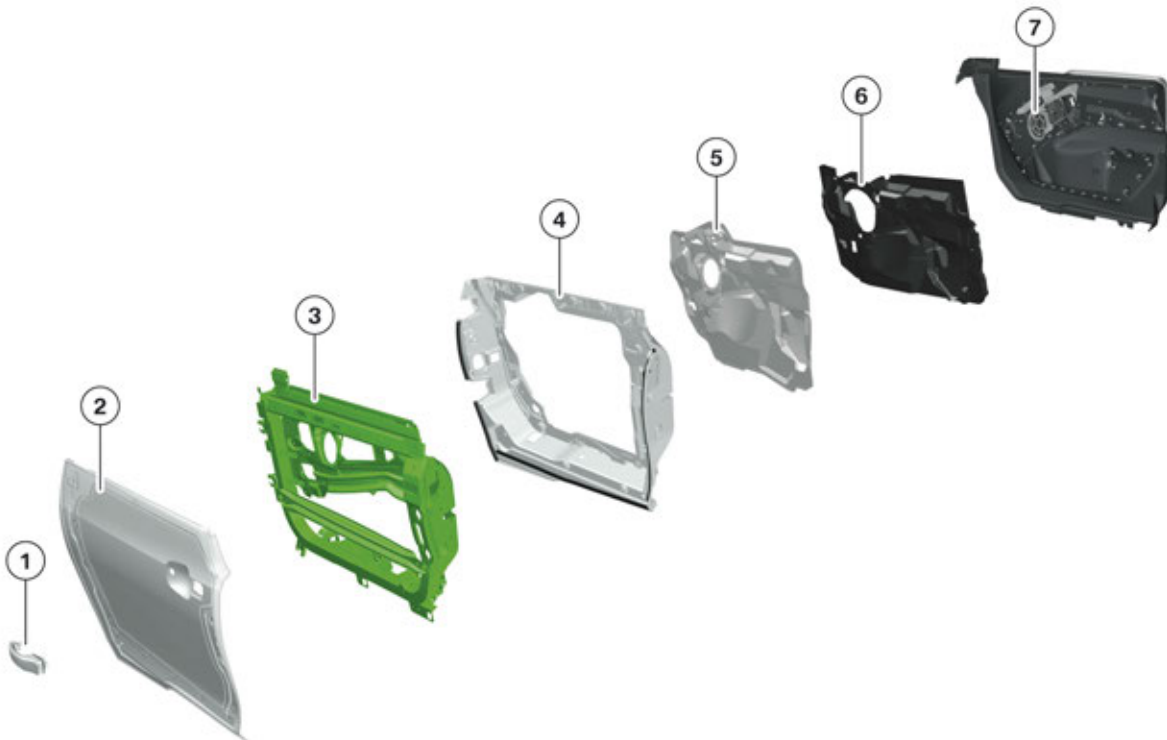

TK12-1109

Exploded view of the front door

Index	Explanation
1	Door handle
2	Outer panels
3	Door window frame
4	Frame trim panel
5	Vapor barrier
6	Sound insulation
7	Interior trim support (with interior components)

The design of the door hinges and door stop reflects the concept of the present day BMW model series and are screwed in each case.

I01 Body Repair Level 1

3. Add-on Body Parts

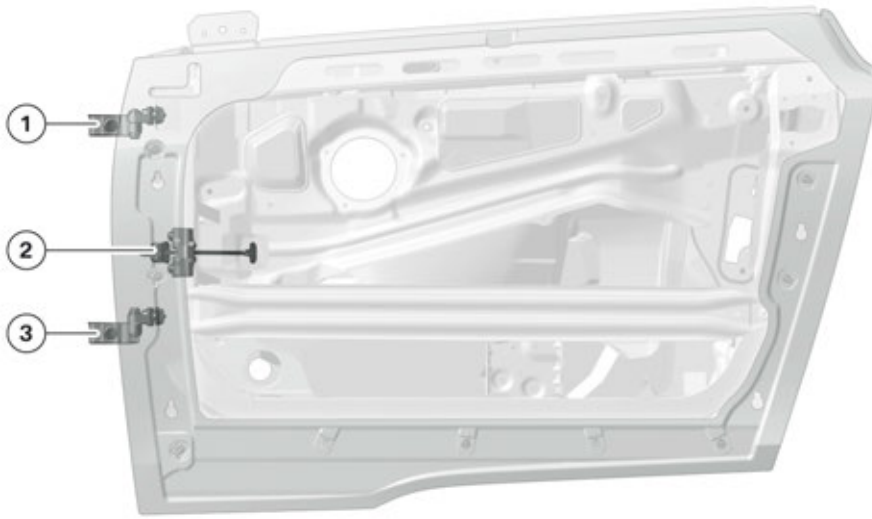

TK13-0299

Front door

Index	Explanation
1	Door hinge at top
2	Door stop
3	Door hinge at bottom

With the i3, the striker for the lock of the front door is attached to the integrated B-pillar at the rear door. The door hinge at the top and bottom is fastened on the body side and to the door window frame by screws.



The tightening torques must be observed with all screw connections. In order to perform the adjustment correctly, the door must be equipped with all mounted parts. When the door is closed, the lock strikers must not strike or rub against the door locks.

The front side windows are frameless. The window regulator is fastened inside the door and has two adjustment points at the bottom section for adjustment of the side window. A new special tool has been developed for the i3.

I01 Body Repair Level 1

3. Add-on Body Parts

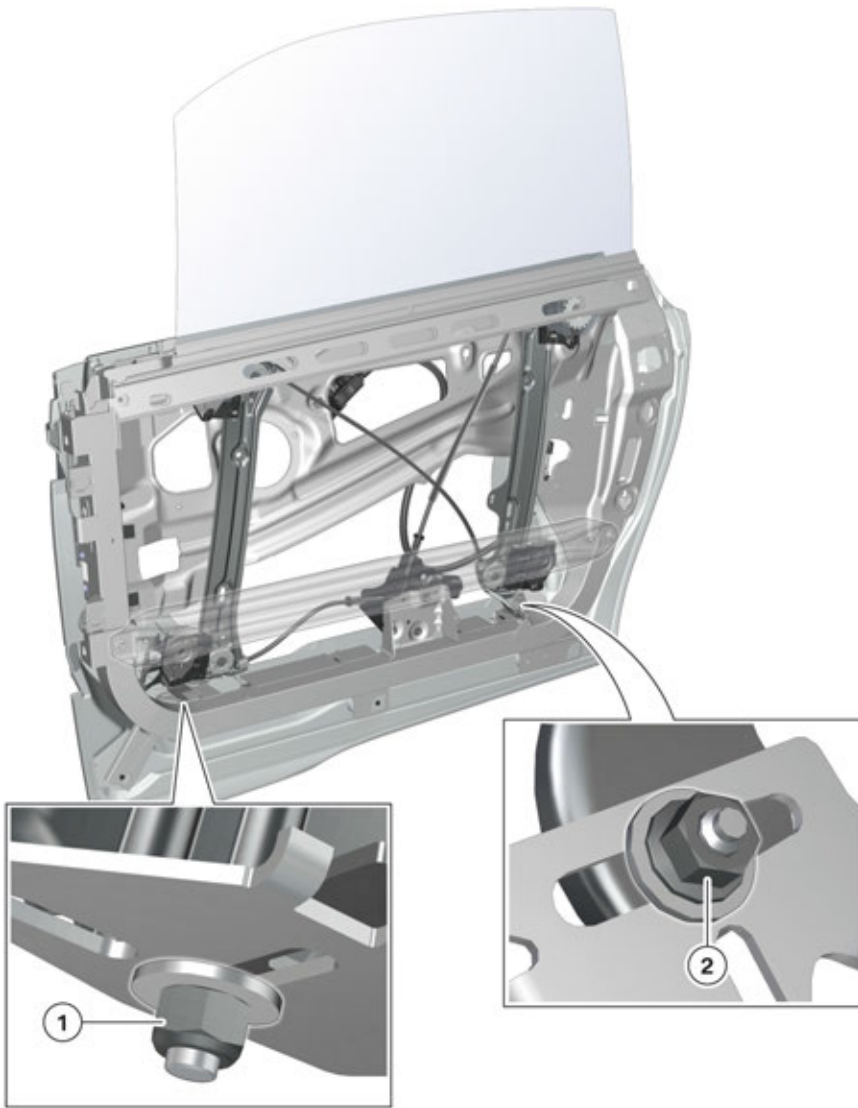

i3 front door, adjustment of window glass

Index	Explanation
1	Adjustment point at front
2	Adjustment point at rear

3.1.2. Rear doors

The rear doors of the i3 consist of several individual components. As is the case with the front door, the door outer panels consists of two parts which are permanently connected at the production stage. The fastening elements are attached to the inner part of the door outer panels.

I01 Body Repair Level 1

3. Add-on Body Parts



TK12-1114

Design of rear door

Index	Explanation
1	Outer panels of rear door
2	Frame trim panel
3	Door window frame
4	Frame trim panel
5	Sound insulation
6	Interior trim support (with interior components)

As the B-pillar of the i3 is integrated into the rear door, the locking system is fastened to the top and underside of the carbon side frame with a door lock. The strikers of the rear door are fastened to the carbon side frame by two screws at the top and three screws at the bottom.



Refer to the repair instructions for the tightening torques to avoid damaging the retaining elements and structural components made of carbon.



When performing the adjustment, be especially careful to ensure that the visible part of the carbon structure is not damaged by projecting parts of the rear door.

I01 Body Repair Level 1

3. Add-on Body Parts

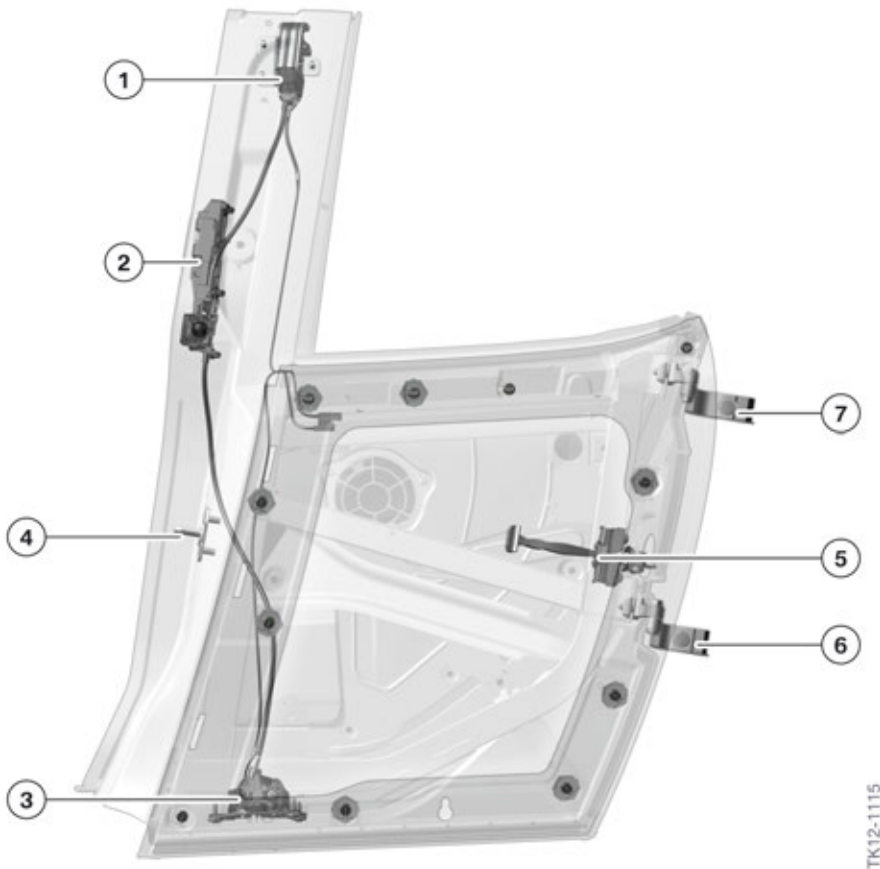

TK12-1115

Mechanism of rear door

Index	Explanation
1	Door lock at top
2	Inner door opener
3	Door lock at bottom
4	Striker
5	Door stop
6	Door hinge at bottom
7	Door hinge at top

The side window of the rear door is screwed to the door window frame with integrated B-pillar. The side window is fixed and cannot be opened.

Two retaining elements are glued to the side window in the front area which is screwed to the integrated B-pillar by these retaining elements. In the rear area, the side window at the top is freestanding and frameless. The side window is attached at the bottom by a plastic guide which is fastened to the door window frame.

I01 Body Repair Level 1

3. Add-on Body Parts

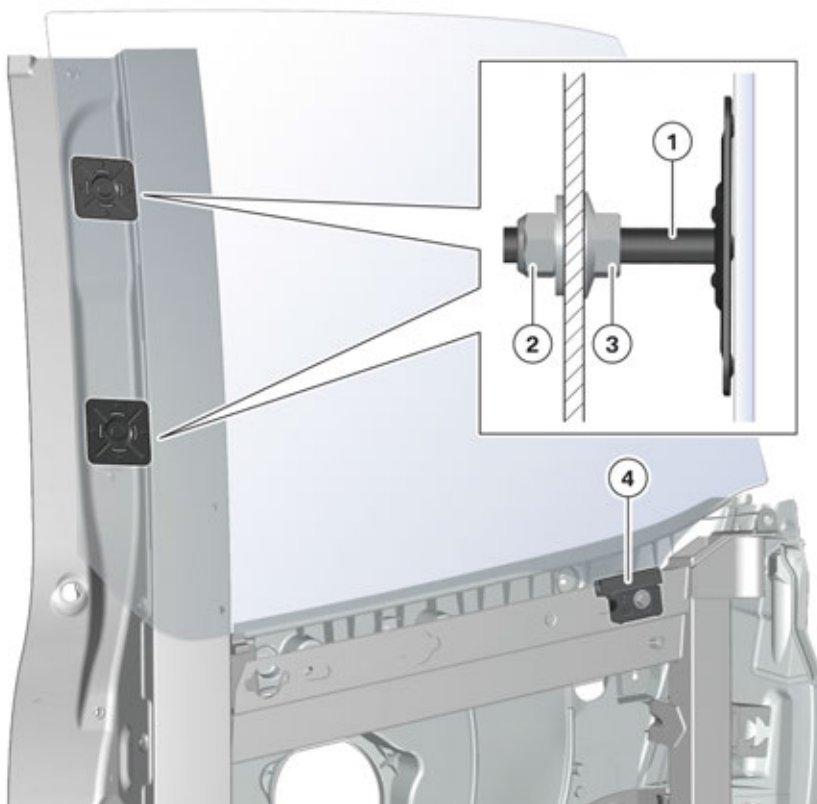

TK13-0315

i3 mounting of rear side window

Index	Explanation
1	Retaining element glued to the side window
2	Inner nut
3	Outer nut
4	Rear guide

3.1.3. Engine compartment lid

The engine compartment lid consists of two plastic parts which are reinforced with an internal frame made of aluminium. These parts are connected permanently during the production stage.

The engine compartment lid is fastened to each of the engine compartment lid hinges with two screws. The engine compartment lid hinges are fastened with screws to the side frame. In order to access the screw connection, the A-pillar cover must be removed. The gas pressure damper is screwed to the engine compartment lid hinge and the wheel arch carrier support.

I01 Body Repair Level 1

3. Add-on Body Parts



Engine compartment lid

Index	Explanation	Material
1	Cover	PC+ABS
2	Outer panels	PP+EPDM
3	Inner section of engine lid compartment	PP+EPDM
4	Reinforcement frame	Aluminium

The engine compartment lid of the i3 can be opened by a button on the A-pillar in the driver's footwell and by a button on the remote key.

The engine compartment lid has four adjustable spacer buffers which ensure that the gap dimensions are correct, and that the engine compartment lid catch opens and closes with ease.

I01 Body Repair Level 1

3. Add-on Body Parts

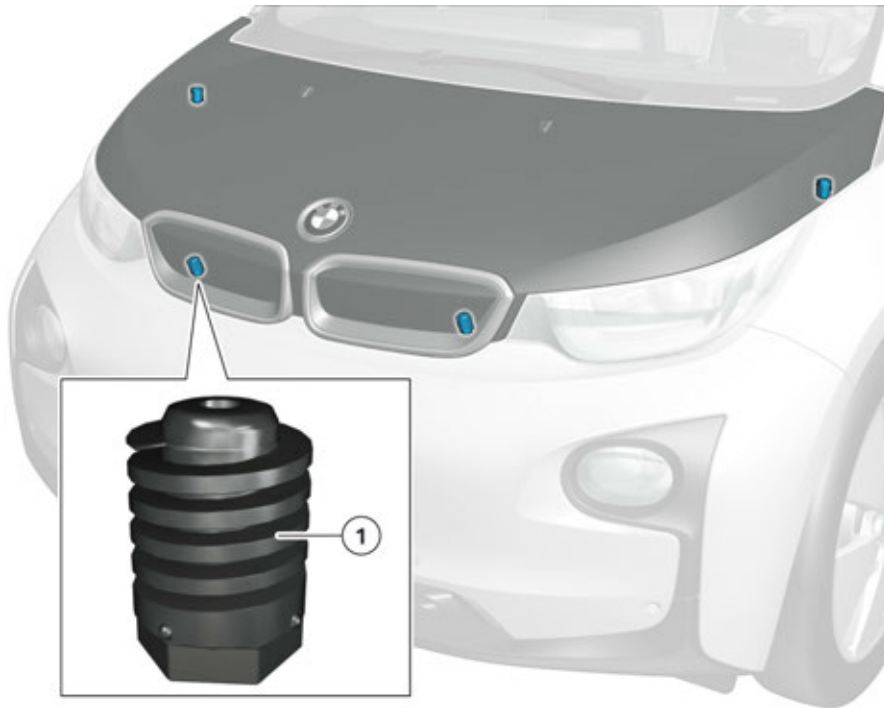

Spacer buffer, engine compartment lid

Index	Explanation
1	Spacer buffer

3.1.4. Tailgate

The rear lights are mounted by screw connections during production and bonded to the outer panels of the tailgate. Changing of the complete rear lights separately is not possible. Individual components can be replaced from the inside by an opening.

I01 Body Repair Level 1

3. Add-on Body Parts

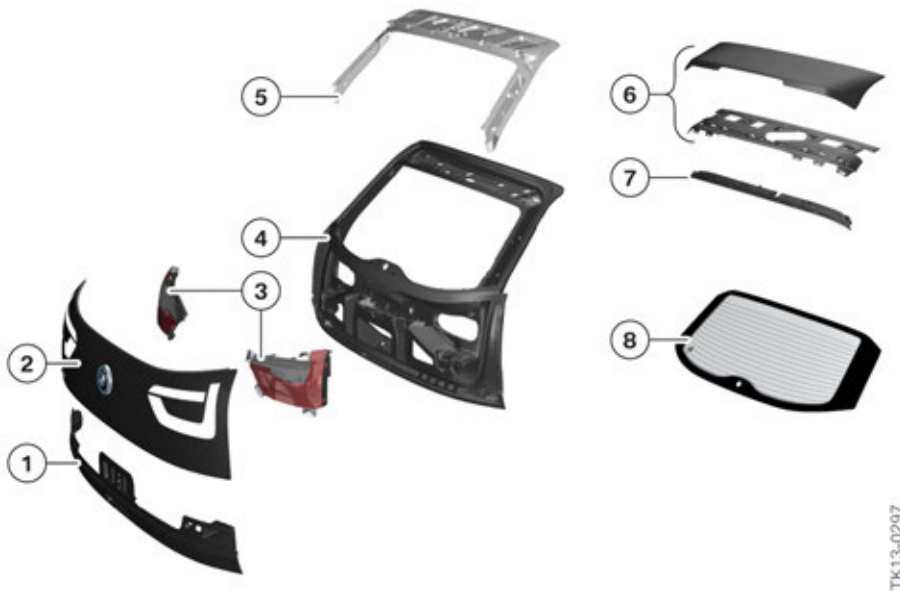

structure of luggage compartment lid

Index	Explanation
1	Outer panels handle strip
2	Tailgate outer panels
3	Rear lights
4	Tailgate inner section
5	Top cover
6	Rear spoiler (two-part, is joined to a component)
7	Rear spoiler trim
8	Lower

Different materials have been used with the tailgate of the i3 in order to satisfy all requirements, e.g. torsional rigidity combined with lightweight construction. These requirements are achieved by using thermoplastics, glass and die-cast aluminium.

The tailgate can be opened from the inside by removing the interior trim. This is required if the closing mechanism or electronics malfunction.

Buffers that determine the distance between the tailgate and body when closed are attached to the tailgate.

I01 Body Repair Level 1

3. Add-on Body Parts



Spacer buffer, tailgate

Index	Explanation
1	Spacer buffer

The hinges of the tailgate are screwed to the Life module. During disassembly, the spray nozzle tube and connector to the wiring harness of the tailgate are detached. For the specific installation and disassembly procedure refer to the repair instructions.

The tailgate replacement part is made up of the following components:

- Top cover
- Outer panels handle strip
- Rear lid lock reinforcement
- Tailgate inner section
- Tailgate outer panels.

I01 Body Repair Level 1

3. Add-on Body Parts



TK13-0316

Scope of replacement parts, tailgate

3.2. Screw-on elements, Drive module

Bumper supports with deformation elements are screwed on to the Drive module of the i3 at the front and rear. If a collision occurs, energy is absorbed by these elements. If damaged, they can be replaced individually.

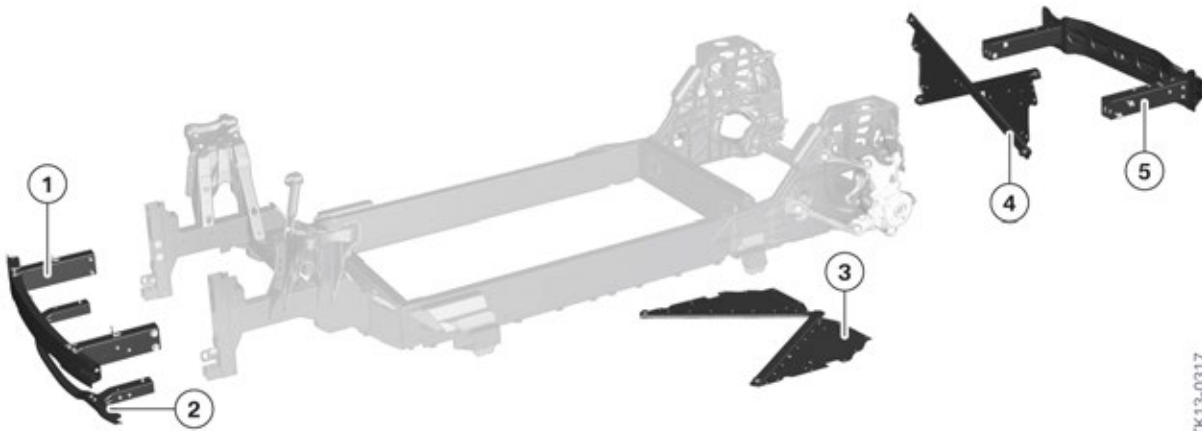

TK13-0317

i3 deformation elements and struts

Index	Explanation
1	Top front support with deformation element
2	Bottom front support with deformation element
3	V-struts
4	Cross brace
5	Rear support with deformation element

I01 Body Repair Level 1

3. Add-on Body Parts

The Drive module is reinforced with struts. The i3 must not be driven without the struts mounted.

3.3. Sliding/tilting sunroof

A slide/tilt sunroof (option 403) is available as optional equipment for the i3. If a slide/tilt sunroof is used, the roof will only be made of carbon up to the slide/tilt sunroof. The slide/tilt sunroof is then framed by trims made of plastic.

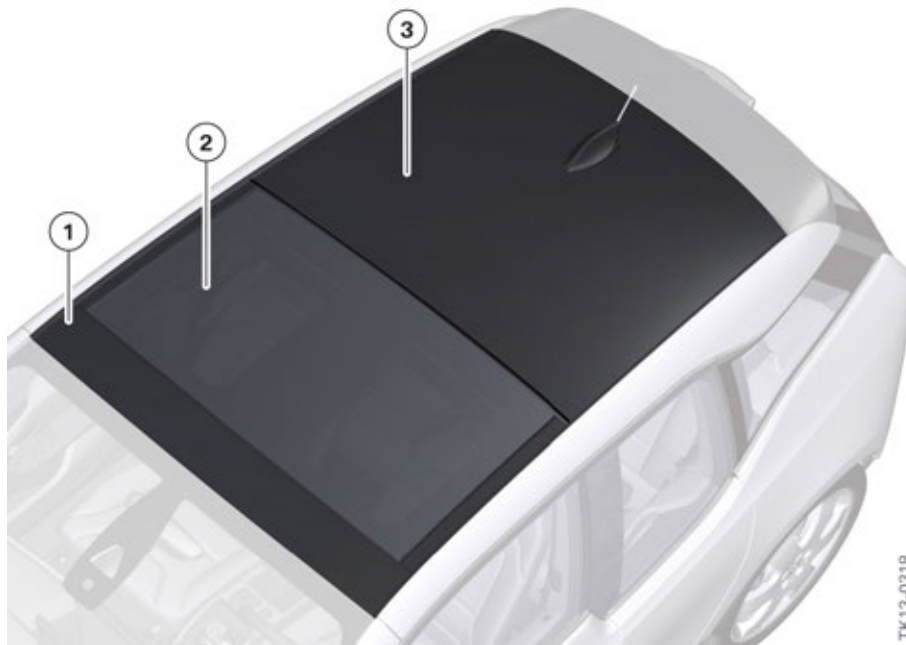

i3 installation of slide/tilt sunroof

Index	Explanation
1	Trims made of plastic
2	Sliding/tilting sunroof
3	Carbon roof

The slide/tilt sunroof is glued with the frame gasket support to the carbon structure (Life module).

The structurally rigid frame gasket support is made up of the following components:

- Integrated mechanism support
- Wind deflector mechanism
- Movable glass lid
- Two manual, adjustable roller sunblind systems
- Wind deflector
- Sealing.

I01 Body Repair Level 1

3. Add-on Body Parts

The main difference in the operating principle is that the glass lid moves outside the vehicle. During the first step, the glass lid is raised/vented at the rear when opening. The slide rail which is centred on the glass lid is then moved backwards. Guide rails are also mounted on the left and right of the glass lid to provide additional stabilization.



The glass lid cannot be fully opened. In this case the slide rail of the mechanism defines the end position of the tilt/slide sunroof opening.



Sliding/tilting sunroof

Index	Explanation
1	Frame gasket support
2	Mechanism support
3	Slide/tilt sunroof drive
4	Glass lid

The position of the glass lid is determined by the screw connections in the horizontal and vertical direction. The precise fit of the glass lid on the gaskets and the exact position in relation to the outer panels must be checked according to the repair instructions following all installation and adjusting procedures. The integrated mechanism carrier is screwed into the structurally rigid frame gasket support. The precise position in this case is determined by centring elements then screwed. The screwed guide rails can guarantee by means of tolerance compensation at the screw holes that the moving components will run without jamming.

The glass lid is screwed centrally and at the side. The screw connections can be accessed from the passenger compartment by the roller sunblind openings. Once the glass lid has been disassembled, all remaining screw connections of the slide/tilt sunroof components such as those on the mechanism support can be accessed to carry out the installation work.

I01 Body Repair Level 1

3. Add-on Body Parts



The roof of the i3 is made of carbon and is permanently bonded to the body. Work on the carbon roof is not part of Body Repair Level 1.

3.4. Windshield

To guarantee a precise fit of the windshield, centering pins which are positioned on the outer sides of the A-pillars in the area of the roofliner are attached to the windshield. On the left side of the vehicle, centering is carried out with a fixed point while on the right side of the vehicle tolerance compensation is provided at the centring pins in the horizontal direction in the form of an elongated hole.

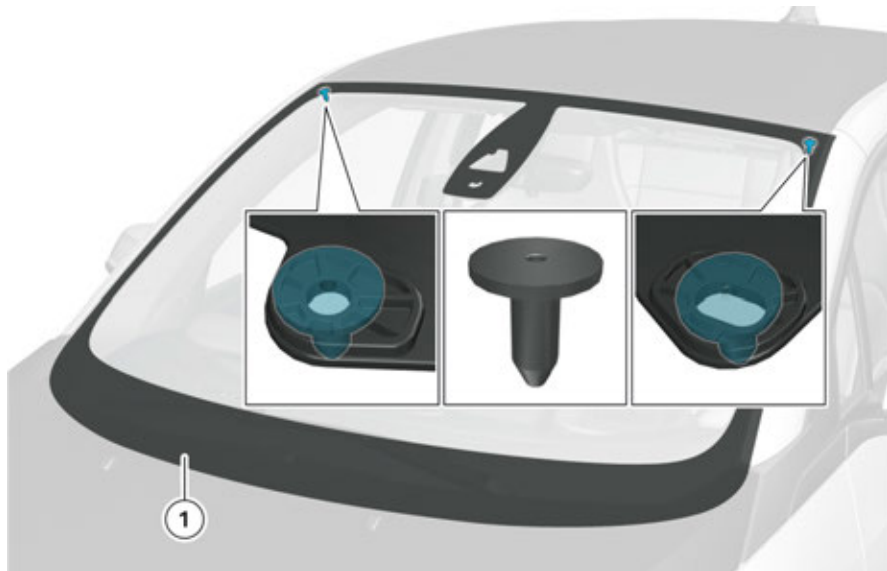

Windscreen with centring element

Index	Explanation
1	Windscreen

The bonded connection between the windshield and body components can be separated using a special tool. The centering pins are also cut through during this process. The new windshield is then reglued and positioned by the centering pins. In doing so, particular attention must be paid to the different materials to which the windshield is attached. In the lower section, the windshield is glued to the steel cowl panel. At the sides, the window glass is glued to plastic strips that are permanently connected to the body structure. The top mounting is at the carbon roof outer panels in vehicles without slide/tilt sunroof, or at the plastic rigid frame of the slide/tilt sunroof in vehicles

I01 Body Repair Level 1

3. Add-on Body Parts

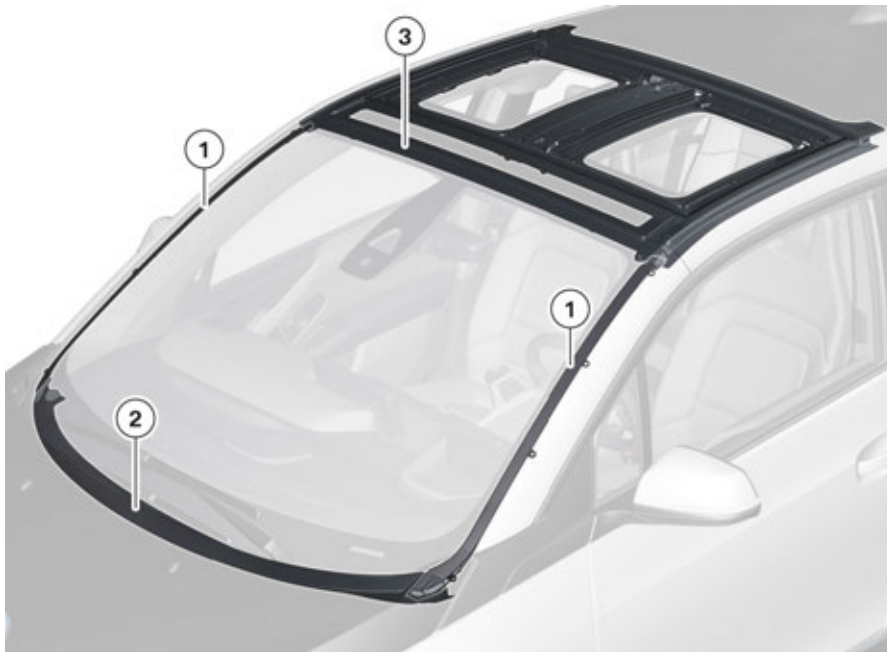

i3 mounting of windscreen in vehicles with slide/tilt sunroof

Index	Explanation
1	Plastic fixing rail at the A-pillar
2	Steel cowl panel at the bottom
3	Plastic frame of slide/tilt sunroof

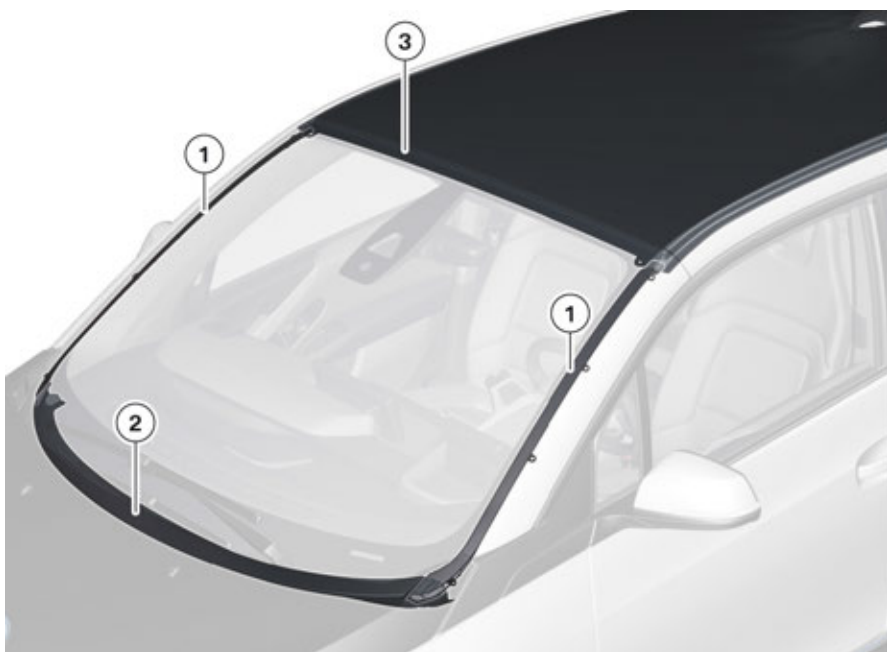

i3 mounting of windscreen in vehicles without slide/tilt sunroof

I01 Body Repair Level 1

3. Add-on Body Parts

Index	Explanation
1	Plastic fixing rail at the A-pillar
2	Steel cowl panel at the bottom
3	Carbon roof

3.5. Rear window

The rear window is glued to the inner section of the tailgate. During disassembly, the electrical plug connection of the rear window must be disconnected and the rear wiper and rear spoiler must be unscrewed. A detailed description of the position and procedure is provided in the repair instructions.



Rear window with electrical plug connections

3.6. Rear side window

The glued side windows are positioned with two centering elements. The centering element specifies the exact position of the side windows during installation. During disassembly, the centering elements attached to the side window are separated together with the adhesive bond.

The rear side window is glued directly to the carbon structure of the Life module. When replacing the side window, care must be taken when breaking the bonded connection.

I01 Body Repair Level 1

3. Add-on Body Parts

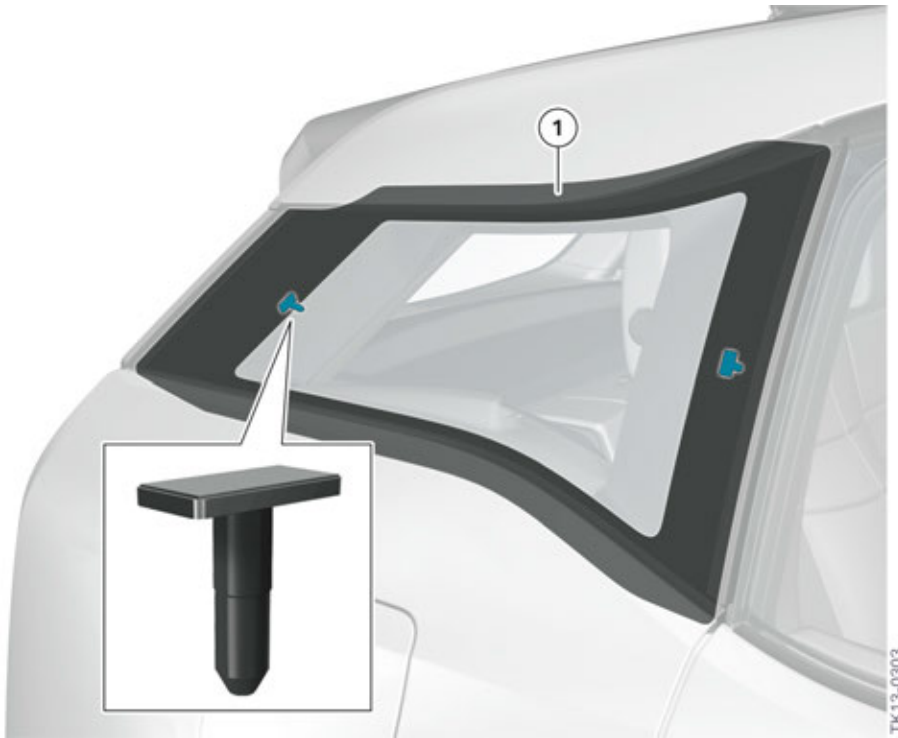

Rear side window with centring elements

Index	Explanation
1	Rear side window

I01 Body Repair Level 1

4. Repair

4.1. Reconditioning of outer panels



Before carrying out any repair work on the outer panels, the retaining elements on the carbon structure components must be inspected. The inspection should also extend to looking for scratches in the surface of components made of carbon.

For this, please observe the currently valid procedure set out in the repair instructions.

Damage such as small cracks and holes in plastic parts of the outer panels, i.e. all components that have not been manufactured from carbon, can be repaired using the repair methods "plastic gluing" and "plastic welding". Please bear in mind that the carbon roof cannot be repaired using these methods.

Plastics can be divided into three groups:

- Thermoplastics
- Thermosetting plastics
- Elastomers.

As the outer panels components of the i3 are made of thermoplastic plastics, only these plastics are taken into consideration. The following table provides an overview of the various thermoplastics.

Thermoplastics	Dept. code
Acrylonitrile butadiene styrene	ABS
Cellulose ketobutyrate	CAB
Cellulose acetate propionate	CAP
Ethylene propylene diene rubber	EPDM
Polyamide	PA
Polycarbonate	PC
Polyethylene	PE
Polyethylene terephthalate	PET
Polymethyl methacrylate	PMMA
Polyoxymethylene	POM
Polypropylene	PP
Polystyrene	PS
Polyvinyl chloride	PVC
Styrene acrylic nitride	SAN



I01 Body Repair Level 1

4. Repair

4.1.1. Plastic bonding

With the plastic bonding repair method, identification of the plastic grade is not required. With this method, galvanized reinforcement strips and a fleece are glued to the reverse face of the component. Following hardening, the repair area on the front face of the component is filled with glue. Once the hardening time is once again complete the surface can be ground to match the original form of the component.

The repair kit comprises the following:

- Two-component adhesive
- Plastic primer
- Cleaning agent and thinner
- Cartridge gun
- Reinforcement fleece
- Reinforcement strip.



Repair kit for plastic gluing

4.1.2. Plastic welding

With the plastic welding repair method, smaller cracks on plastic components (thermoplastics) made of PP+EPDM and ABS for example can be repaired. A plastic repair kit with soldering iron and welding adapter is used in the BMW workshop environment. A specific welding wire is used for this, depending on the material composition of the component.



Not all types of plastic can be welded. Also observe the current notes in the repair instructions.

The repair kit comprises the following:

- Soldering iron with welding adapter
- Welding wire PP
- Welding wire ABS
- Universal welding wire

I01 Body Repair Level 1

4. Repair

- 110/220 V voltage converter
- Aluminium adhesive tape
- Cutter knife.



Repair kit for plastic welding

The advantage when compared to the plastic gluing repair method is that an adhesive hardening time is not required and fewer operations are necessary.

The distinguishing characteristic of thermoplastics is that they, similar to metals, can be re-fused and their geometry modified.

Examples of thermoplastics are:

4.2. Repair of fixing rails

For economic reasons, the fixing rails of the i3 are not repaired. If damaged, the fixing rails, and possibly their mountings, are replaced.



Refer to the repair instructions for the prescribed tightening torques to avoid damaging the retaining elements and structural components made of carbon.

When the fixing rails are replaced, the components of the carbon structure must be inspected for damage. The inspection should also extend to looking for scratches in the surface of components made of carbon.

4.3. Repairing door window frames

When repairing the door outer panels or parts in the area surrounding the door window frame, the door window frame must be inspected for damage. For this, please observe the currently valid procedure set out in the repair instructions.

The holders of the outer panels at the door window frame may be reshaped if slightly deformed, providing the weld seam is still fully intact.

I01 Body Repair Level 1

4. Repair



Please observe the current notes in the repair instructions regarding the repair of aluminium components.

4.4. Repair of screwed deformation elements

If damaged, the screwed deformation elements at the Drive module must not be repaired.



Please observe the current notes in the repair instructions regarding the repair of aluminium components.

4.5. Repair of ground support points



The tightening torques listed in the repair instructions must be adhered to during all installation work, otherwise the resulting damage can be extremely costly.

If ground support points at the Drive module are damaged these can be repaired. For this, please observe the current repair procedure in the repair instructions.

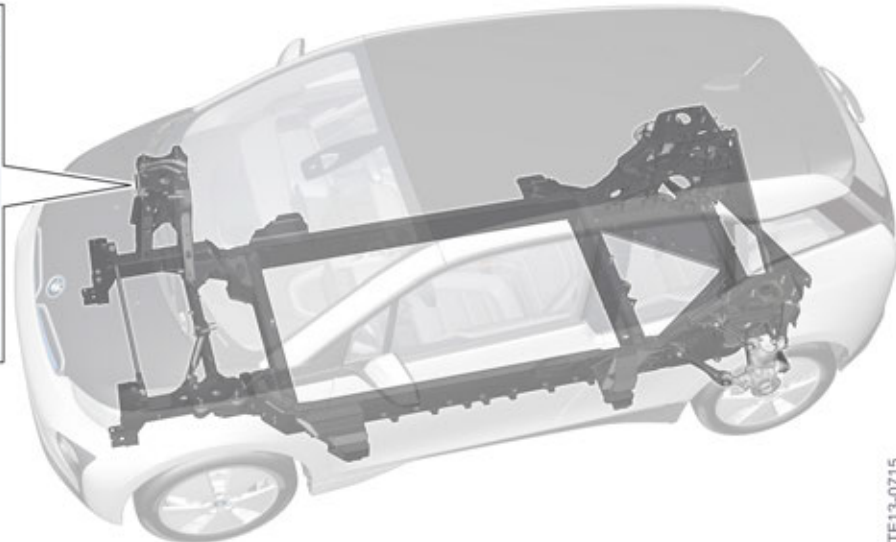

TE13-0715

i3 ground support point at the Drive module

I01 Body Repair Level 1

5. Body Damage

5.1. Notes

As new materials and new fastening concepts are being used, this results in new repair methods. The following notes must be observed. Special care must be taken when carrying out work at the vehicle due to the use of high-voltage components in the i3.

To ensure that the i3 is repaired professionally and safely, special procedures and methods have been developed.

Please also find out about the repair work that your facility is permitted to carry out. The Service formats referred to at the outset must be observed without compromise.



Danger to life!

When carrying out work, observe the detailed procedure and sequence specified in the repair instructions that are valid at the time of repair.



Danger to life!

Before repair work on a vehicle that has been involved in an accident can be carried out, it must be ensured by appropriately qualified personnel that the vehicle is intrinsically safe.



When assessing damage at a i3, the current procedure in the repair instructions must be observed.

This procedure is markedly different to the procedure followed up till now. Please familiarize yourself with the relevant contents beforehand.

Based on current information, the following elements are subject to a special inspection following damage which must be observed without fail:

- Carbon body components (Life module)
- Surfaces of body components made of carbon
- Retaining elements at body components made of carbon (e.g. rivet nuts, holders for mounting the outer panels, attachment points of hinges)
- Structural components made of aluminium (Drive module).



Bayerische Motorenwerke Aktiengesellschaft
Qualifizierung und Training
Röntgenstraße 7
85716 Unterschleißheim, Germany